

## ■ Sechskantmutter M10 SW 17

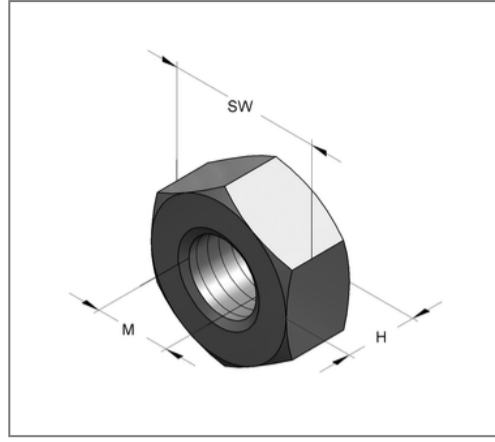
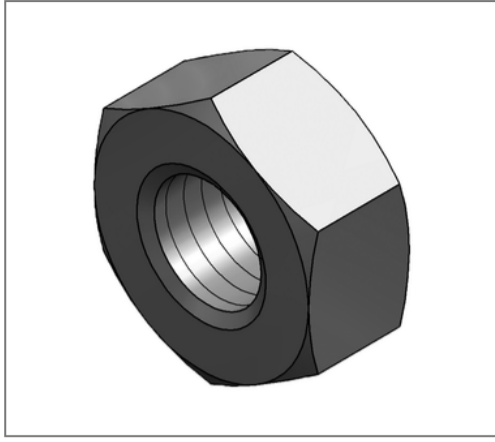

### Kaufmännische Details

Artikelnummer	4120477
EAN/GTIN	4250928438898
VPE	100 St
Mengeneinheit	St
Gewicht	0,0120 kg/St
Rabattgruppe	05-412
Preiseinheit	100

### QR Code



### Technische Daten

Material	Stahl
Oberfläche	galvanisch verzinkt

### Produktdetails

Höhe H	8 mm
Gewinde M	M10
Schlüsselweite SW	17