

■ CENTUM T-Lock M12 x 40 mm

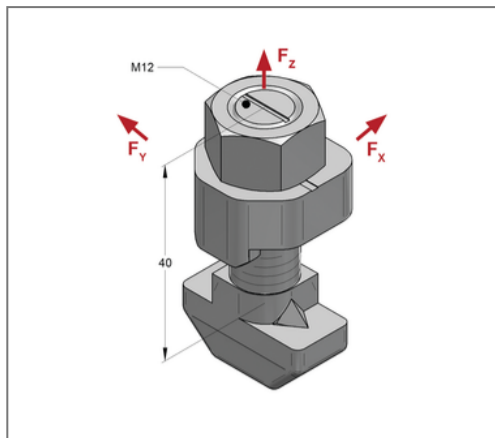
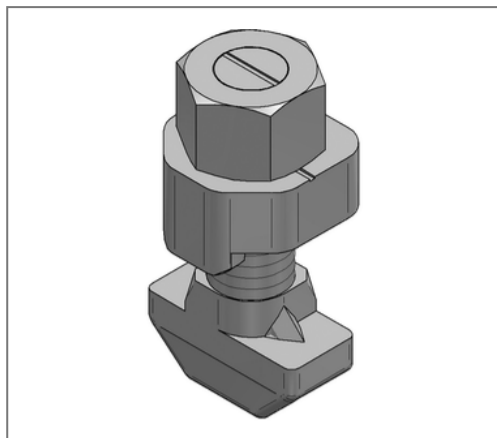

Kaufmännische Details

Artikelnummer	1610011000
EAN/GTIN	4250928436658
VPE	50 St
Mengeneinheit	St
Gewicht	0,120 kg/St
Rabattgruppe	14-161
Preiseinheit	1

QR Code



Zertifizierungen



Ausführung und Montage

Einsatzgebiet	Für formschlüssige Montage in Verbindung mit MEFA Montageprofil CENTUM®.
Ausführung	formschlüssige Verbindung
Profiltyp	XL 80, XL 100, XL 120, XL 200

Technische Daten

Material	Stahl
Oberfläche	Zink-Nickel
Festigkeitsklasse	10.9

Produktdetails

Gewinde	M12
Länge Gewinde	40 mm
Anzugsmoment XL 100	120 Nm
Anzugsmoment XL 80	90 Nm
Baulänge	34 mm
Breite Hammerkopf	12,5 mm
Durchmesser U-Scheibe	23,5 mm
Länge Hammerkopf	28 mm
Stärke Hammerkopf	12 mm
Stärke Scheibe	10 mm