

## ■ Distanzrohr-Abschnitt 1/2" x 150 mm gvz

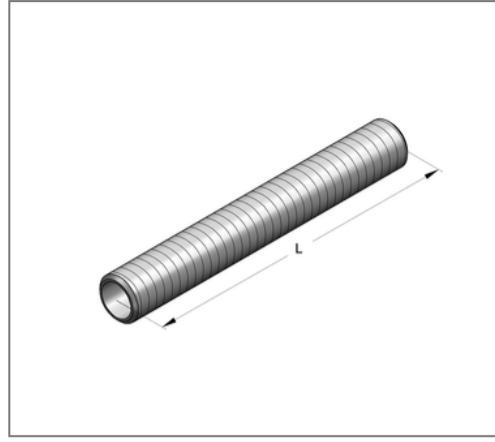
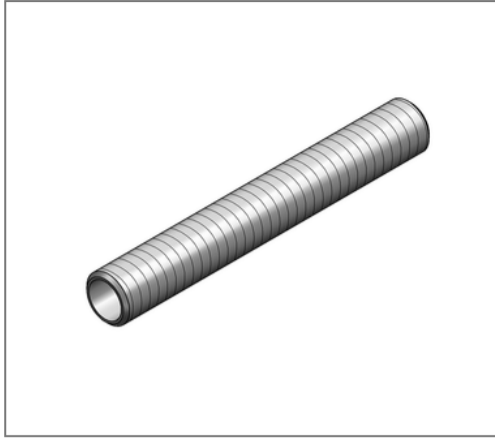

### Kaufmännische Details

Artikelnummer	07070150
EAN/GTIN	4250928456755
VPE	25 St
Mengeneinheit	St
Gewicht	0,168 kg/St
Rabattgruppe	05-070
Preiseinheit	1

### QR Code



### Technische Daten

Material	Stahl
Oberfläche	galvanisch verzinkt

### Produktdetails

Gewinde	1/2"
Länge L	150 mm