

■ Fixpoint support for downstream piping Set SML DN 150 / 160 mm Wall distance 100 - 300 mm

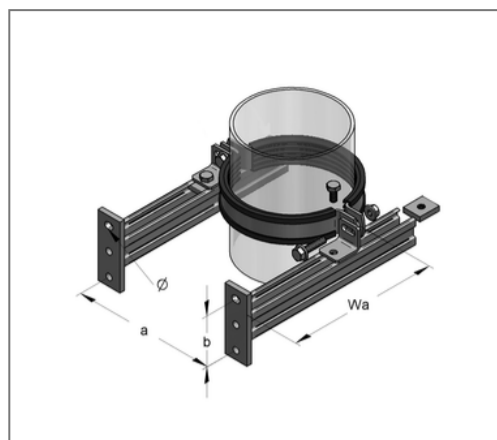
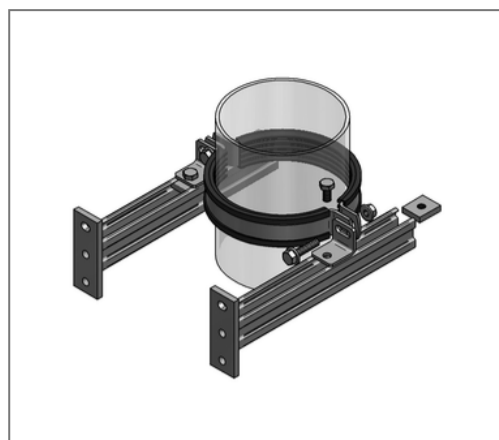

Commercial details

Part no.	4501500
EAN/GTIN	4250928439567
Packing unit	1 pcs
Quantity unit	pcs
Weight	2,79 kg/pc
Product group	03-450
Price unit	1

QR code



Certification



Specification

Application	Brackets for the manufacture of a support for area
	sewage downpipes.

Technical data

Material	Steel
Surface	galvanized
Sound insulation lining	TPE
min. temperature resistance	-35 °C
max. temperature resistance	100 °C
Thickness material sound insulation lining	6 mm
Class	B2
Colour sound insulation lining	black
Material C-profile	S235JR

Product details

Outer pipe diameter	160 mm
Nominal pipe diameter	150 mm
Hole distance b	80 mm
Length console	300 mm
load F1	4,16 kN
load F2	2,08 kN
Console type	Stex 35/42
Screw type	M10x20
Pipe clamp type	Maxima PSM

Product details

Distance measure a	230 mm
Type distance angle	Distance angle single 42x35x4
Type of threaded plate	M10 35x30
max. wall distance WA	300 mm
min. wall distance WA	100 mm
Elongated hole	11x15 mm