

■ Double holder with threaded pin Center distance L 65 mm

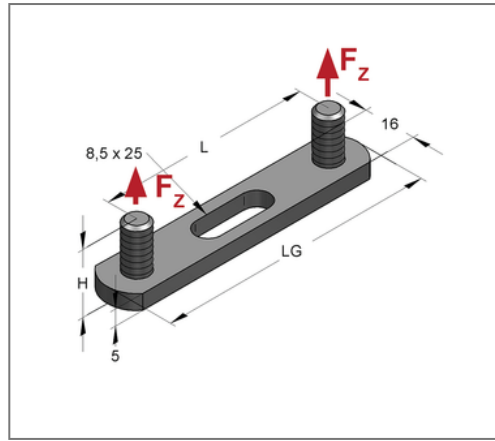
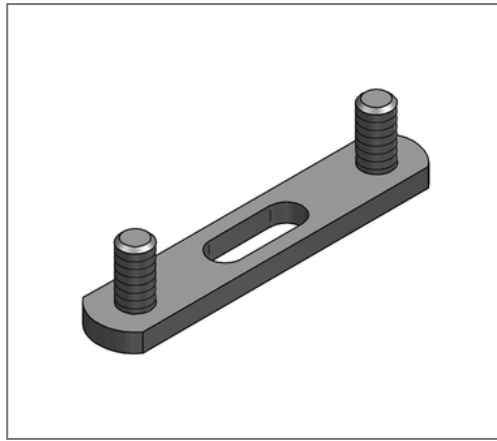

Commercial details

Part no.	0760048
EAN/GTIN	4250928417343
Packing unit	50 pcs
Quantity unit	pcs
Weight	0,0690 kg/pc
Product group	05-076
Price unit	100

QR code



Specification

Application Holder with fixed grub screws for fastening two parallel pipelines in combination with pipe clamps.

Technical data

Material	Steel
Material type	S235
Surface	galvanized

Product details

Center distance L	65 mm
Width	16 mm
Höhe H	20 mm
Length LG	85 mm
Threaded bolt type	M8x20
load F_z	0,2 kN