

■ Conical stud V A M8 Length 110 mm Steel

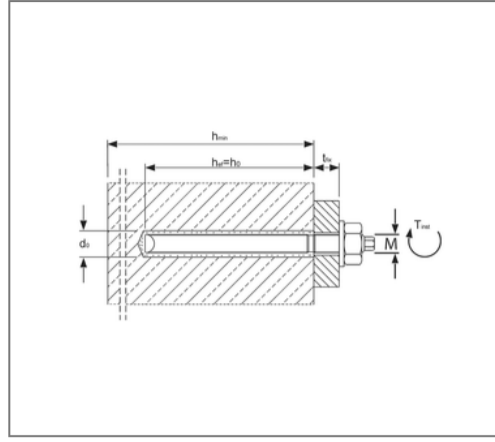

Commercial details

Part no.	221821101101
EAN/GTIN	4043315019288
Packing unit	10 pcs
Quantity unit	pcs
Weight	0,0430 kg/pc
Product group	07-221
Price unit	1

QR code

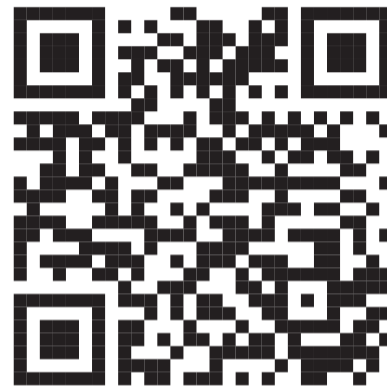

Certification



Specification

Application area	for non-cracked concrete C12/15 to C50/60.
Brand	MKT

Product details

Drill diameter	10 mm
Drilling hole depth	80 mm
max. clamping thickness	20 mm
Depth of anchoring	80 mm
Wrench size nut	13
Wrench size anchor rod	5
Type of mortar cartridge	V-P 8
Length	110 mm
Thread	M8

Technical data

Material	Steel
Surface	galvanized

Remark

Delivery time	3 working days, ex works
---------------	--------------------------