

## ■ Conical stud V A M12 Length 160 mm Steel

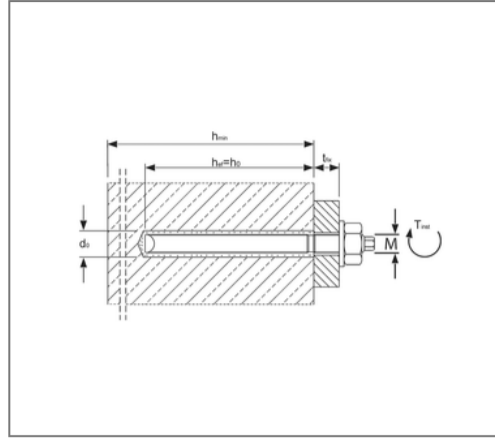

### Commercial details

|               |               |
|---------------|---------------|
| Part no.      | 221821306101  |
| EAN/GTIN      | 4043315020512 |
| Packing unit  | 10 pcs        |
| Quantity unit | pcs           |
| Weight        | 0,137 kg/pc   |
| Product group | 07-221        |
| Price unit    | 1             |

### QR code



### Certification



### Specification

|                  |  |
|------------------|--|
| Application area | for non-cracked concrete C12/15 to C50/60. |
| Brand            | MKT  |

### Product details

|                          |        |
|--------------------------|--------|
| Drill diameter           | 14 mm  |
| Drilling hole depth      | 110 mm |
| max. clamping thickness  | 35 mm  |
| Depth of anchoring       | 110 mm |
| Wrench size nut          | 19     |
| Wrench size anchor rod   | 8      |
| Type of mortar cartridge | V-P 12 |
| Length                   | 160 mm |
| Thread                   | M12    |

### Technical data

|          |            |
|----------|------------|
| Material | Steel      |
| Surface  | galvanized |

### Remark

|               |                          |
|---------------|--------------------------|
| Delivery time | 3 working days, ex works |
|---------------|--------------------------|