

■ Conical stud V A Length 165 mm Steel

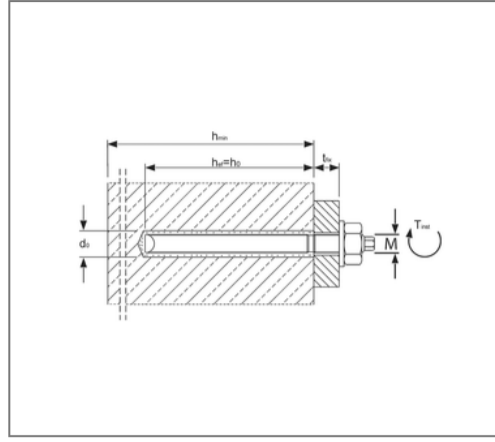

Commercial details

Part no.	221821507101
EAN/GTIN	4043315021564
Packing unit	10 pcs
Quantity unit	pcs
Weight	0,277 kg/pc
Product group	07-221
Price unit	1

QR code



Certification



Specification

Application area	for non-cracked concrete C12/15 to C50/60.
Brand	MKT

Product details

Drill diameter	18 mm
Drilling hole depth	125 mm
max. clamping thickness	20 mm
Depth of anchoring	125 mm
Wrench size nut	24
Wrench size anchor rod	12
Type of mortar cartridge	V-P 16
Length	165 mm
Thread	M16

Technical data

Material	Steel
Surface	galvanized

Remark

Delivery time	3 working days, ex works
---------------	--------------------------