

■ Conical stud VMZ A 80 M12 Length 110 mm

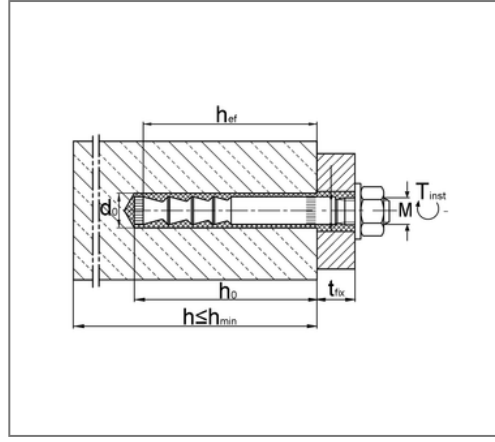

Commercial details

Part no.	221832305101
EAN/GTIN	4043315053473
Packing unit	10 pcs
Quantity unit	pcs
Weight	0,117 kg/pc
Product group	07-221
Price unit	1

QR code



Certification



Specification

Brand	MKT
Application area	Für gerissenen und ungerissenen Beton C20/25 bis C50/60.
Fire protection	yes
Application area	Concrete

Technical data

Material	Steel
Surface	galvanized

Product details

Thread	M12
Length	110 mm
Wrench size	19
Tightening torque	25 Nm
Drilling hole depth	85 mm
Length dowel	110 mm
max. clamping thickness	10 mm
Setting depth	84 mm

Remark

Delivery time	3 working days, ex works
---------------	--------------------------