

## ■ Conical stud VMZ kt1.A 100 M12 Length 180 mm

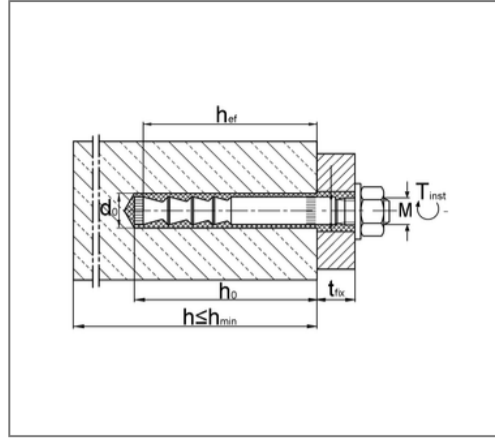

### Commercial details

Part no.	221832385101
EAN/GTIN	4043315053596
Packing unit	10 pcs
Quantity unit	pcs
Weight	0,175 kg/pc
Product group	07-221
Price unit	1

### QR code



### Certification



### Specification

Brand	MKT
Application area	Für gerissenen und ungerissenen Beton C20/25 bis C50/60.
Fire protection	yes
Application area	Concrete

### Technical data

Material	Steel
Surface	galvanized

### Product details

Thread	M12
Length	180 mm
Wrench size	19
Tightening torque	30 Nm
Drilling hole depth	105 mm
Length dowel	180 mm
max. clamping thickness	60 mm
Setting depth	104 mm

### Remark

Delivery time	3 working days, ex works
---------------	--------------------------