

## ■ Pipe clamp HDC 30x2,5 40 - 45 mm M8 unlined

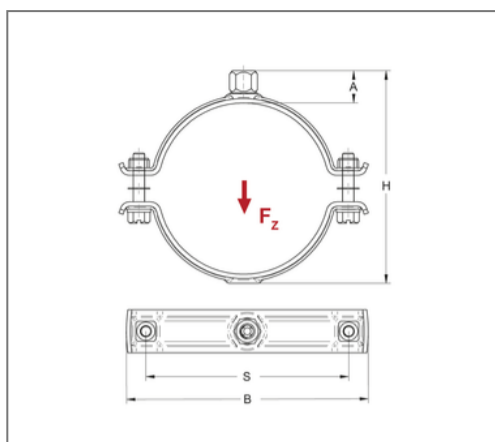

### Commercial details

Part no.	47300040
EAN/GTIN	4250928458179
Packing unit	50 pcs
Quantity unit	pcs
Weight	0,174 kg/pc
Product group	12-034
Price unit	100

### QR code



### Certification



### Specification

Brand	Jiangmen Eurofix
Application	Pipe clamp with connection thread according to area sprinkler guidelines for Sprinkler systems.
Specification	two-part
Connection	M8

### Technical data

Material	Steel
Surface	galvanized
Sound insulation lining	unlined

### Product details

Center distance S	66 mm
Connection height A	16 mm
Width B	88 mm
Höhe H	65 mm
Material dimension	30x2,5 mm
load $F_z$	1,5 kN
min. outside pipe diameter	40 mm
max. outer pipe diameter	45 mm
Outside pipe diameter inch	1 1/4 inch
Closure screw	val.Verschlusschraube.M8